



MXA310

Specifications

Table of Contents

MXA310 Specifications	3	Frequency Response	4
Specifications	3	IP Ports and Protocols	9

MXA310

Specifications

Specifications

All specifications measured from cardioid polar pattern. Values for all patterns are within ± 3 dB of these specifications unless otherwise noted.

Polar Pattern

All channels independently adjustable

Cardioid, Hypercardioid, Supercardioid, Toroid, Omnidirectional, Bidirectional

Connector Type

RJ45

Power Requirements

Power over Ethernet (PoE), Class 0

Power Consumption

4W, maximum

Weight

362 g (0.8 lbs)

Dimensions

H x W x D

3.6 x 13.4 x 13.4 cm (1.4 x 5.3 x 5.3 in.)

control application

HTML5 Browser-based

Operating Temperature Range

-6.7°C (20°F) to 40°C (104°F)

Storage Temperature Range

-29°C (-20°F) to 74°C (165°F)

Audio

Frequency Response

100 to 20,000 Hz

Dante Digital Output

Channel Count	5 total channels (4 independent transmit channels, 1 Automatic mixing transmit channel)
----------------------	---

Sampling Rate	48 kHz
Bit Depth	24

Sensitivity

at 1 kHz, , -15 dB Gain Setting

-21 dBFS/Pa

Maximum SPL

1 kHz at 1% THD, -15 dB Gain Setting

115.2 dB SPL

Signal-To-Noise Ratio

Ref. 94 dB SPL at 1 kHz, -15 dB Gain Setting

Cardioid	75 dB
Toroid	67 dB

Latency

Not including Dante latency

<1 ms

Self Noise

-15 dB Gain Setting

Cardioid	19.2 dB SPL-A
Toroid	26.8 dB SPL-A

Dynamic Range

-15 dB Gain Setting

Cardioid	96 dB
Toroid	90 dB SPL

Built-in Digital Signal Processing

Per Channel	Equalizer (4-band Parametric) , Mute, Gain (140 dB range)
System	Automatic mixing, Low-Cut Filter (-12 dB/octave @150 Hz)

Networking

Cable Requirements

Cat 5e or higher (shielded cable recommended)

Frequency Response

Frequency response measured from a distance of 2 feet (61 cm).

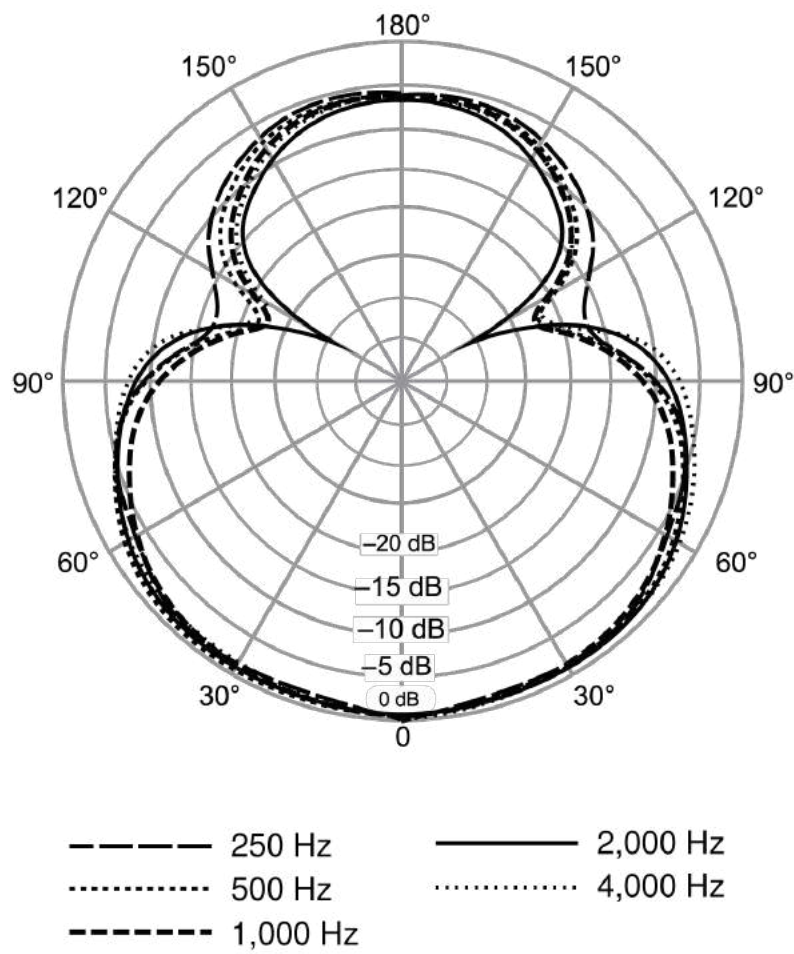
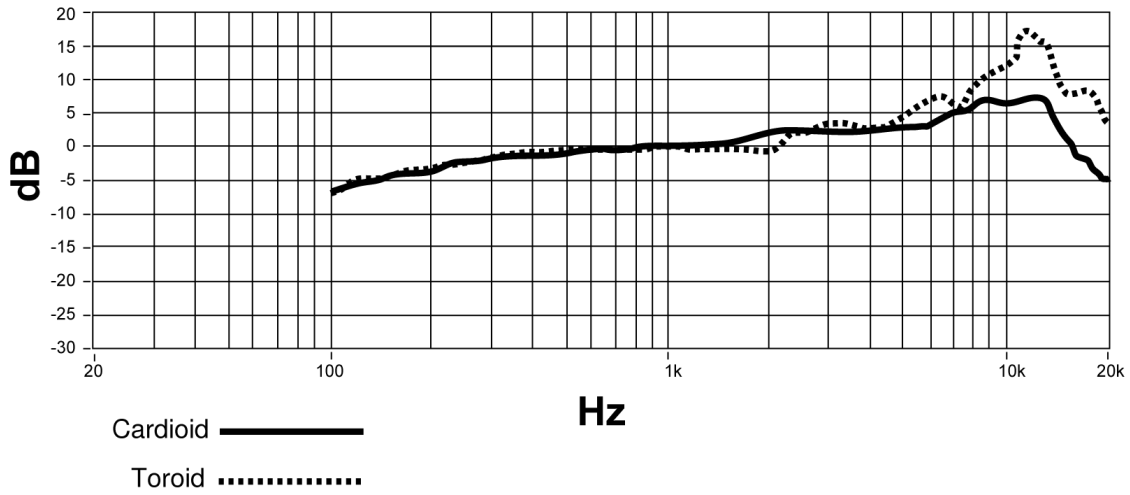

Hypercardioid

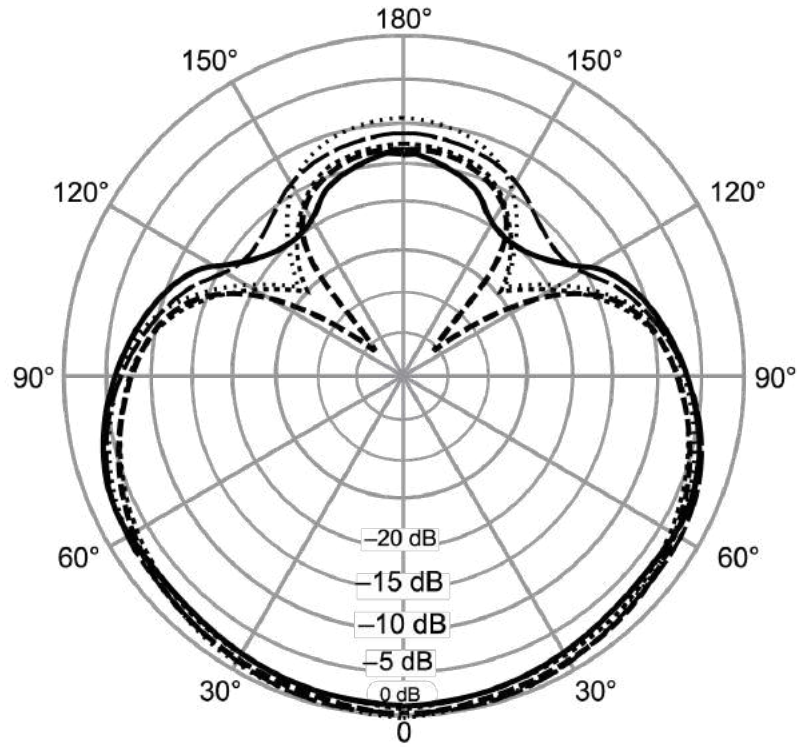

- 250 Hz
- 500 Hz
- 1,000 Hz
- 2,000 Hz
- 4,000 Hz

Supercardioid

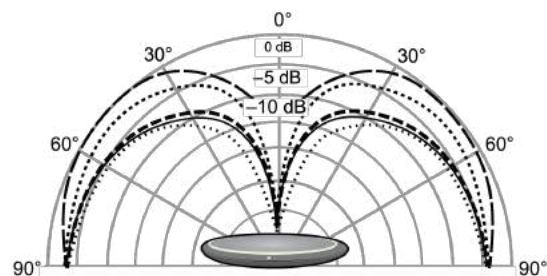
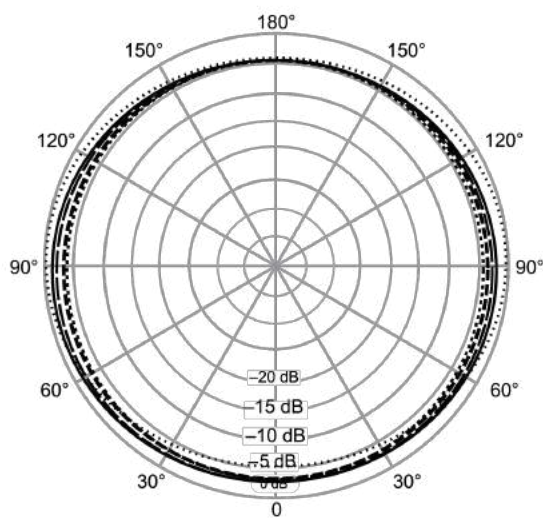

- 250 Hz
- 500 Hz
- 1,000 Hz
- 2,000 Hz
- 4,000 Hz

Toroid

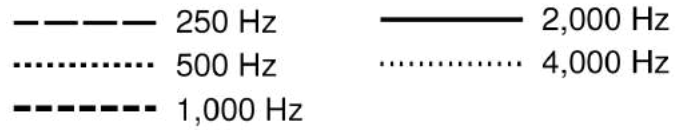
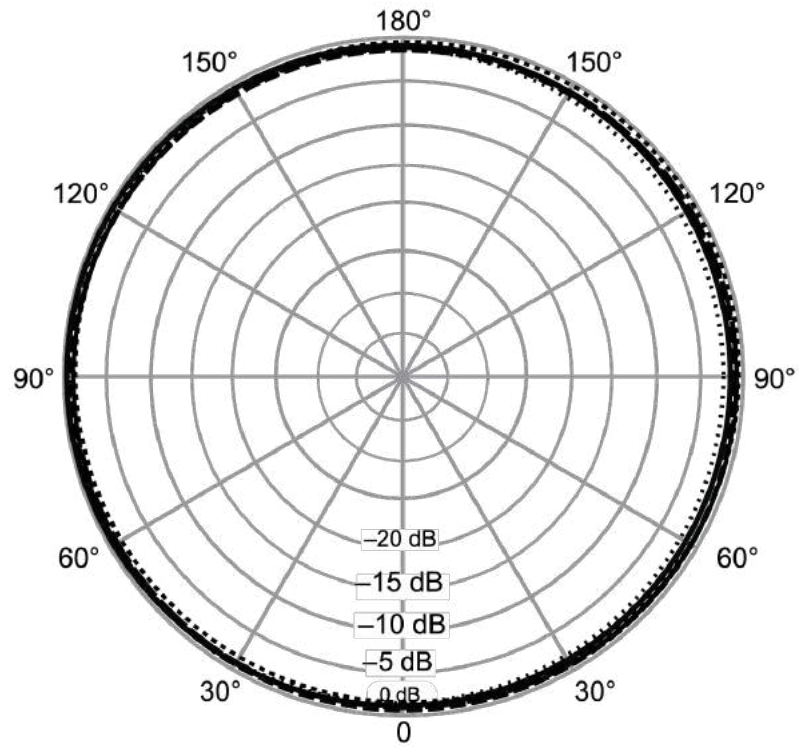

Omnidirectional

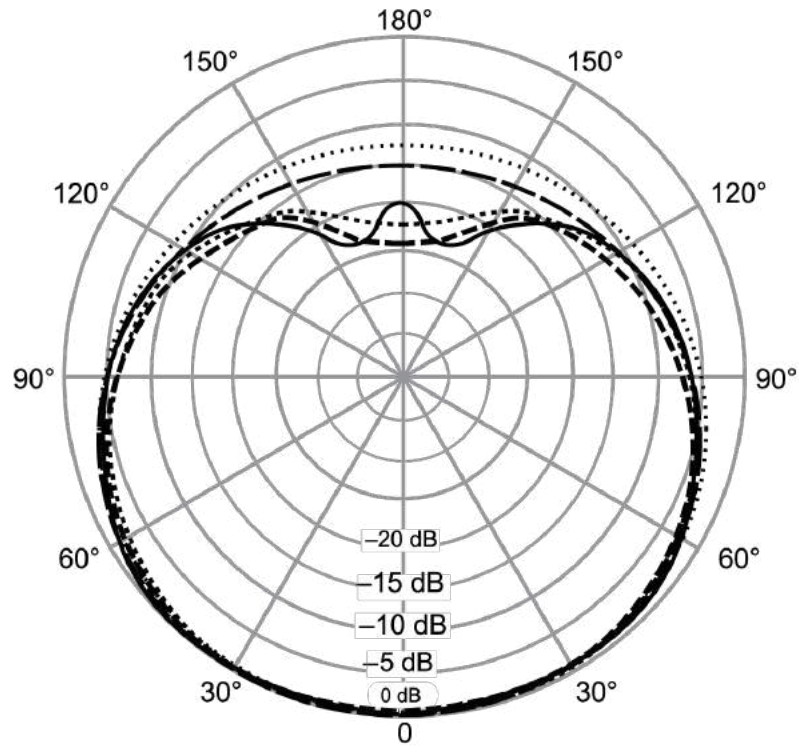

- 250 Hz
- 500 Hz
- . - . 1,000 Hz
- 2,000 Hz
- 4,000 Hz

Cardioid

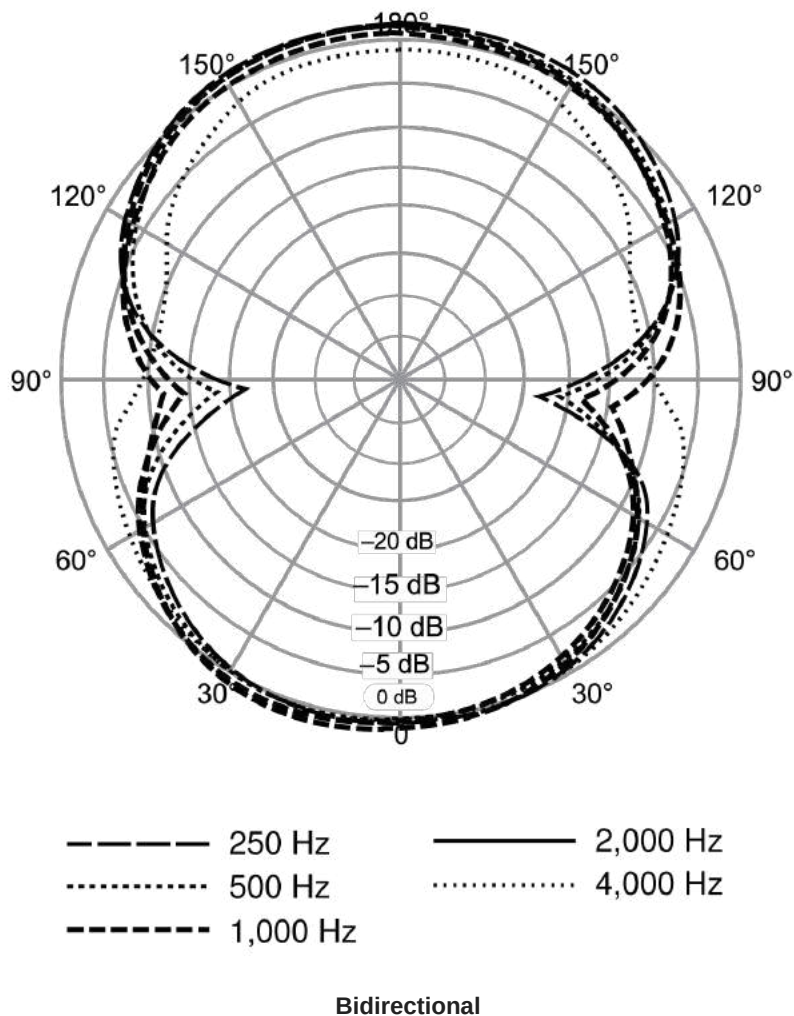

IP Ports and Protocols

Shure Control

Port	TCP/UDP	Protocol	Description	Factory Default
21	tcp	FTP	Required for firmware updates (otherwise closed)	Closed
22	tcp	SSH	Not supported	Closed
23	tcp	Telnet	Standard console interface	Closed
68	udp	DHCP	Dynamic Host Configuration Protocol	Open
80*	tcp	HTTP	Required to launch embedded web server	Open
427	tcp/udp	SLP [†]	Required for inter-device communication	Open

Port	TCP/UDP	Protocol	Description	Factory Default
443	tcp	HTTPS	Not supported	Closed
161	tcp	SNMP	Not supported	Closed
162	tcp	SNMP	Not supported	Closed
2202	tcp	ASCII	Required for 3rd party control strings	Open
5353	udp	mDNS [†]	Required for device discovery	Open
5568	udp	SDT [†]	Required for inter-device communication	Open
8023	tcp	Telnet	Debug console interface	Password
8180*	tcp	HTML	Required for web application	Open
8427	udp	Multicast SLP [†]	Required for inter-device communication	Open
64000	tcp	Telnet	Required for Shure firmware update	Open

Dante Audio & Controller

Port	TCP/UDP	Protocol	Description
162	udp	SNMP	Used by Dante
[319-320]*	udp	PTP [†]	Dante clocking
2203	udp	Custom	Required for packet bridge
4321, 14336-14600	udp	Dante	Dante audio
[4440, 4444, 4455]*	udp	Dante	Dante audio routing
5353	udp	mDNS [†]	Used by Dante
[8700-8706, 8800]*	udp	Dante	Dante Control and Monitoring
8751	udp	Dante	Dante Controller
16000-65536	udp	Dante	Used by Dante

*These ports must be open on the PC or control system to access the device through a firewall.

[†]These protocols require multicast. Ensure multicast has been correctly configured for your network.